

# 304F Ball Valve

3-Piece Full Port  
ISO 5211 Direct Mount Pad



For Automated &  
Manual Service

---

General Chemical

---

Industrial

---

and Other Corrosion  
Resistant Applications

# The 304F Series Ball Valve

The 304F series ball valve incorporates several innovative design features for improved process performance. The uniform bore diameter improves flow rates and minimizes pressure drop through the valve. The dual pattern ISO 5211 mounting pad facilitates direct mounting of pneumatic and electric actuators. In combination with our high-cycle stem packing system, the 304F series ball valve provides an ideal choice for all your automation requirements.

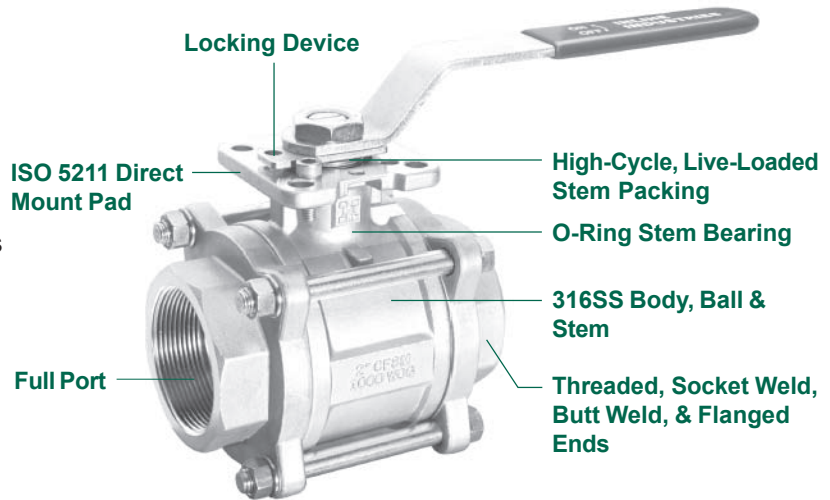

## Standard Features and Benefits

- **Dual Pattern ISO 5211 Direct Mount Pad**
  - No bracket or drive coupling needed for automation
  - Eliminates exposed moving parts for safer work environment
  - Direct drive eliminates play and improves actuator positioning
  - Dual pattern pad fits a wide range of actuator sizes
- **High-Cycle, Live-Loaded Stem Packing**
  - Ensures tight seal
  - Extends service life
- **O-Ring Stem Bearing**
  - Maintains stem alignment
  - Reduces packing side-loading and wear
  - Enhances stem seal
- **Blow-Out-Proof Stem**
  - Stem is bottom loaded to prevent removal when valve is in service
- **Full Port Design**
  - Improves flow resulting in increased process efficiencies
- **3-Piece Construction**
  - Easy to repair
- **End Cap Alignment Step**
  - Ensures easy and proper alignment between mating parts
- **Investment Cast**
  - Improves dimensional control and reduces porosity
- **Locking Device**
  - Enables plant personnel to secure valve in open or closed position when manually operated
- **Standard Seats and Seals Suitable for 150 PSI Saturated Steam**

## Options

- End connections available in NPT, socket weld, butt weld, flanged, compression, tank bottom, and grooved

304F Pressure / Temperature Chart  
(RTFE Seats)

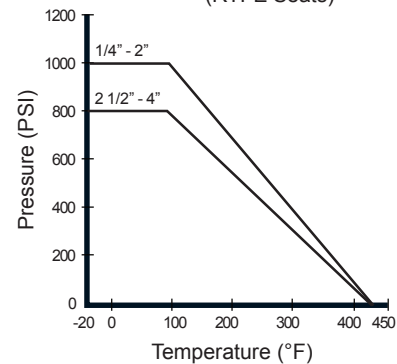

## Operating Conditions

- Temperature range (RTFE):  
-20°F ~ 420°F
- Maximum pressure (RTFE):  
1000 PSI WOG (1/4" - 2"),  
800 PSI WOG (2 1/2" - 4")

## Specifications

- All valves shell and seat tested to ANSI/ASME B16.34 and API 598
- All materials comply with applicable ASTM material specifications
- End connections: All to B16.34; NPT to B1.20.1; socket weld to B16.11; butt weld to B16.25; flanged to B16.5

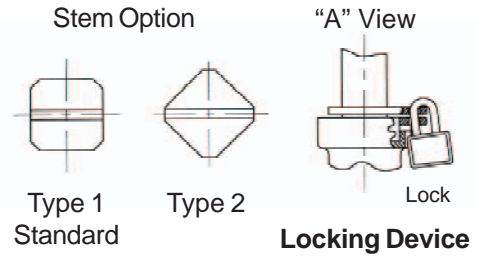
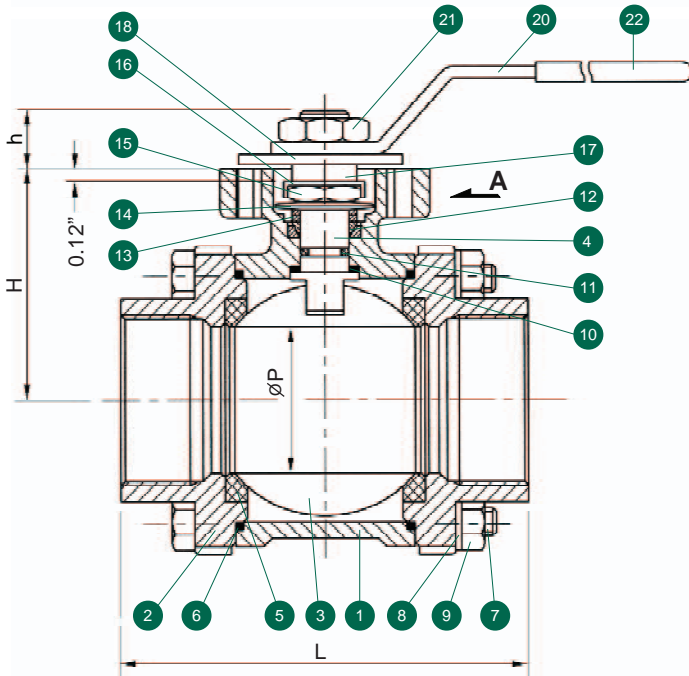
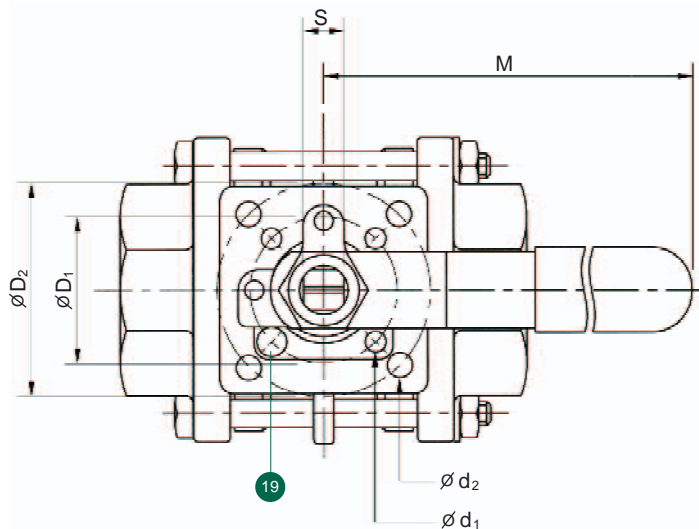

Valve Components			
#	Part Name	Material	Qty.
1	Body	A351 Gr. CF8M	1
2	End Cap	A351 Gr. CF8M	2
3	Ball	316SS	1
4	Stem	316SS	1
5	Seat	RTFE (15% C.F.)	2
6	Body Seal	PTFE	2
7	Body Bolt	304SS	4*
8	Spring Washer	304SS	4*
9	Body Nut	304SS	4*
10	Thrust Washer	PEEK	1
11	Stem O-Ring	Viton 90	1
12	Stem Packing Set	PTFE	1
13	Packing Gland	304SS	1
14	Belleville Washer	301SS	2
15	Gland Nut	304SS	1
16	Gland Nut Lock Washer	304SS	1
17	Stem Spacer	304SS	2
18	Stop Plate	304SS	1
19	Stop Pin	304SS	1
20	Handle	304SS	1
21	Handle Nut	304SS	1
22	Handle Cover	Vinyl	1

\* 4" Valve: 6 Nuts, Washers and Bolts

Dimensions (Inches)												
Size	L	$\phi P$	M	H	h	D <sub>1</sub>	D <sub>2</sub>	d <sub>1</sub>	d <sub>2</sub>	S	ISO 5211 Pattern	Wt. (lbs)
1/4	2.42	0.44	4.92	1.46	0.35	1.42	1.65	0.23	0.23	0.35	F03 / F04*	1.4
3/8	2.42	0.49	4.92	1.46	0.35	1.42	1.65	0.23	0.23	0.35	F03 / F04*	1.3
1/2	2.42	0.59	4.92	1.46	0.35	1.42	1.65	0.23	0.23	0.35	F03 / F04*	1.3
3/4	3.09	0.79	4.92	1.65	0.35	1.42	1.65	0.23	0.23	0.35	F03 / F04*	2.1
1	3.35	0.98	5.91	1.91	0.51	1.65	1.97	0.23	0.28	0.43	F04 / F05*	2.7
1 1/4	3.96	1.25	5.91	2.11	0.51	1.65	1.97	0.23	0.28	0.43	F04 / F05*	3.9
1 1/2	4.45	1.50	7.86	2.48	0.63	1.97	2.76	0.28	0.36	0.55	F05 / F07*	5.5
2	5.12	1.97	7.86	3.00	0.63	1.97	2.76	0.28	0.36	0.55	F05 / F07*	9.0
2 1/2	6.54	2.56	11.61	3.62	0.79	2.76	4.01	0.37	0.45	0.67	F07 / F10*	18.4
3	7.40	3.15	11.61	4.02	0.79	2.76	4.01	0.37	0.45	0.67	F07 / F10*	27.5
4	8.50	3.94	13.39	5.24	0.98	4.02	4.92	0.45	0.49	0.87	F10 / F12*	51.4

\* Direct mount with stem adapter bushing



Direct Mount Products



Automation Systems

## 304F Ordering Information

Example: 2" 3-Piece Full Port Ball Valve with ISO 5211 Direct Mount Pad, Lever Handle and Locking Device, 316SS Body and Trim, RTFE (15% C.F.) Seats, PTFE Seals, NPT Ends

Valve Series	Valve Size	Body Material	End Material	Ball Material	Stem Material	Seat	Seal	End Connection	Port	Ball Config.
<b>304F - Full Port</b>	2 1/4" 3 3/8" 5 1/2"	6 - A351 Gr. CF8M (316)	6 - A351 Gr. CF8M (316) 2 - A216 Gr. WCB 3 - A351 Gr. CF3M (316L)	6 - A351 Gr. CF8M (316)	6 - A351 Gr. CF8M (316)	C - RTFE (15% C.F.) F - 50% 316SS Filled PTFE T - PTFE U - UHMWPE	T - PTFE U - UHMWPE	T - NPT S - Socket Weld 5 - Butt Weld Sch. 5** 1 - Butt Weld Sch. 10** 4 - Butt Weld Sch. 40** G - Grooved A - 150# Flanged B - 300# Flanged P - Compression K - Tank Bottom	2 - 2 Way	S - Straight Port 7 - ASEV Ball
<b>304C - Compression</b>	7 3/4" A 1" B 1 1/4" C 1 1/2" D 2" E 2 1/2" F 3" G 4"									

Due to continuous product development, information may change without notice.

\*\* 316L - Standard Material



Distributed by:

### INLINE INDUSTRIES, INC.

4701-A Littlejohn Street  
Baldwin Park, CA 91706  
Tel: (800) 568-8998  
(626) 813-6188  
Fax: (626) 813-6186  
www.ballvalve.com  
info@ballvalve.com

© 2011 Inline Industries. All rights reserved.

1106.1