

317F Sanitary Ball Valve

3-Piece Tube Full Port

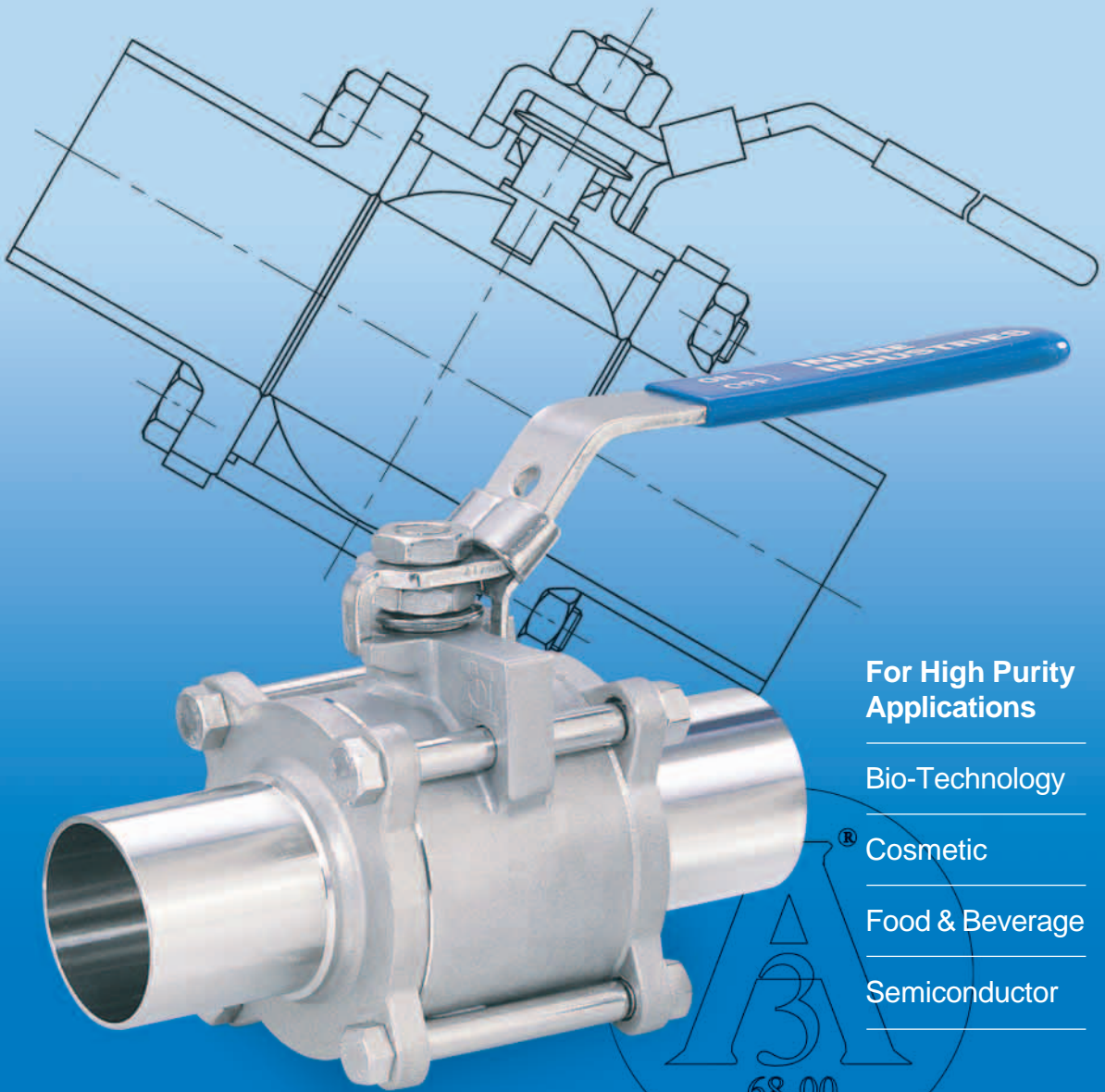

For High Purity
Applications

Bio-Technology

Cosmetic

Food & Beverage

Semiconductor

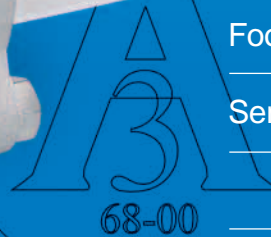

The 317F Series Sanitary Ball Valve

The 317F series combines tube full port construction with a variety of sanitary end connections to deliver outstanding performance in high purity applications. The valve's uniform bore diameter and polished internal surfaces improve flow characteristics and eliminate pooling of potential contaminants.

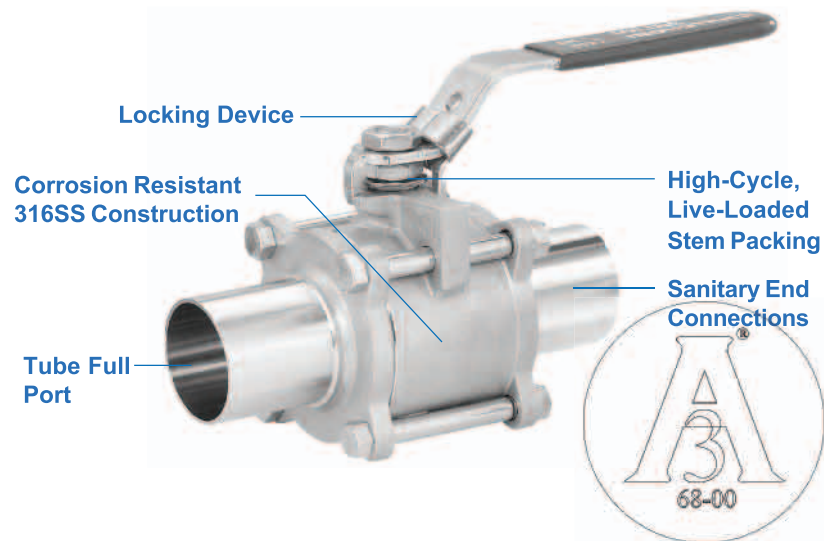

Standard Features and Benefits

- **Tube Full Port Design**
True tube full port construction eliminates pooling of process media and improves flow characteristics for greater efficiency
- **High-Cycle, Live-Loaded Stem Packing**
Ensures tight seal
Extends service life
- **3-Piece Swing-in-Place Construction**
Easy to repair in service line
- **Made of Corrosion-Resistant 316SS (A-351 Gr. CF8M) with 316L SS (A-351 Gr. CF3M) Weld Ends**
One valve can be used for many service conditions
- **Blow-Out-Proof Stem**
Stem is bottom loaded to prevent removal when valve is in service
- **Locking Device**
Enables plant personnel to secure valve in open or closed position when manually operated
- **Investment Cast**
Improves dimensional control and reduces porosity
- **Internal Surfaces Roll Burnished Prior to Final Polish**
Reduces surface porosity
Improves surface finish

Options

- Clamp, tube butt weld, extended tube butt weld ends
- Polish and electro-polish to custom specifications
- Cavity filled seats

317 Pressure / Temperature Chart
(PTFE Seats)

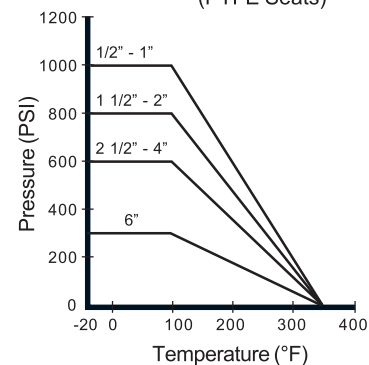

Operating Conditions

- Temperature Range (PTFE):
-20°F - 350°F
- Maximum Pressure (PTFE):
1000 PSI (1/2" - 1"), 800 PSI (1 1/2" - 2"), 600 PSI (2 1/2" - 4"), 300 PSI (6")

Specifications

- Valves inspected and tested to API 598 and meet ANSI/FCI70-2 Class VI and MSS SP-61 seat leakage requirements
- All materials comply with applicable ASTM material specifications and USDA and FDA material requirements
- Material test reports available upon request

1/2" ~ 4"

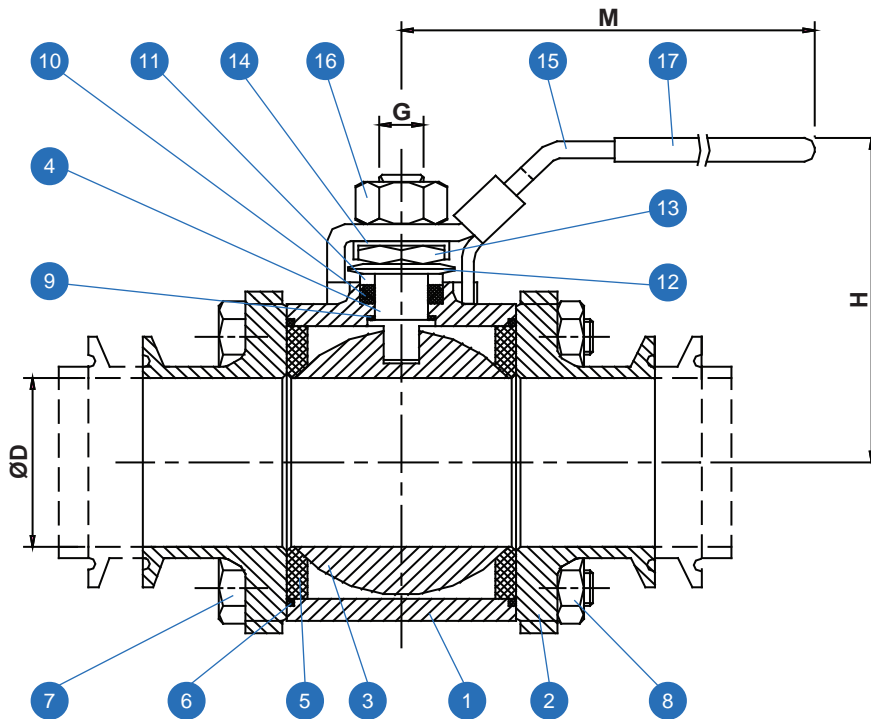
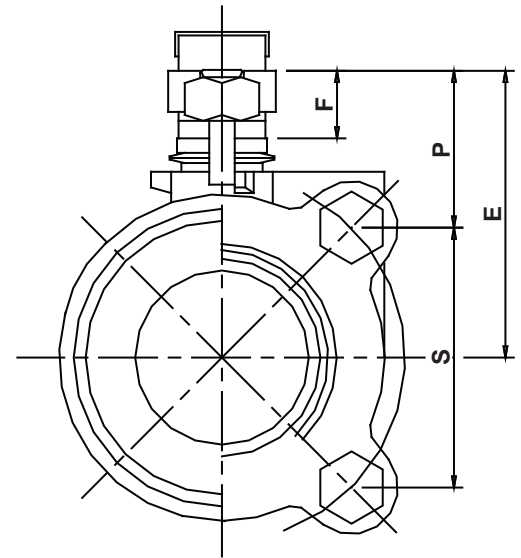
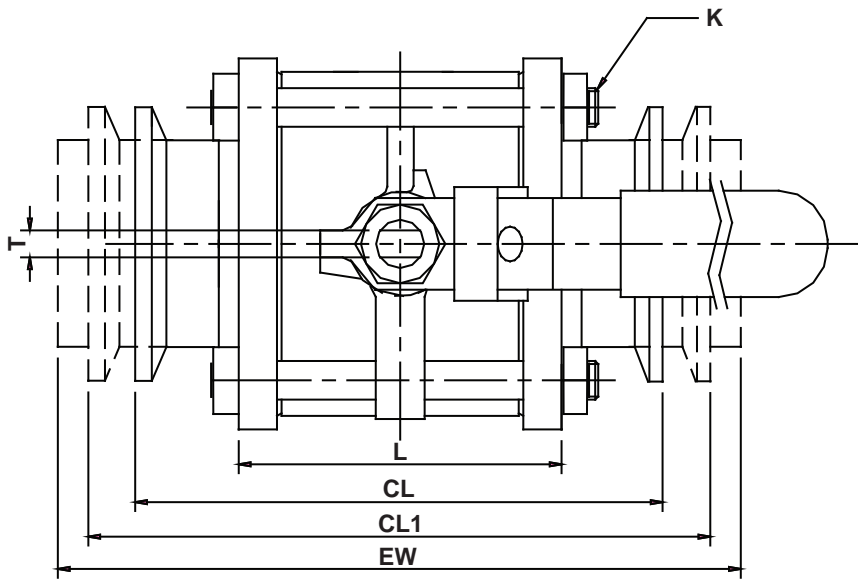

Valve Components			
#	Part Name	Material	Qty.
1	Body	A351 Gr. CF8M	1
2	End Cap	A351 Gr. CF3M	2
3	Ball	316SS	1
4	Stem	316SS	1
5	Seat	PTFE	2
6	Body Seal	PTFE	2
7	Body Bolt	304SS	4 ^{1,2}
8	Body Nut	304SS	4 ^{1,2}
9	Thrust Washer	PTFE	1
10	Stem Packing Set	PTFE	1
11	Packing Gland	304SS	1
12	Belleville Washer	301SS	2
13	Gland Nut	304SS	1
14	Gland Nut Lock Washer	304SS	1
15	Handle	304SS	1
16	Handle Nut	304SS	1
17	Handle Cover	Vinyl	1

¹ 4" Valve: 6 Nuts and Bolts

² 6" Valve: 8 Nuts and Bolts

Dimensions (Inches)

Size	CL	CL1	EW	D	H	M	E	F	K	S	P	L	G	T	Weight (lbs) Clamp End
1/2	3.50	-	4.90	0.38	1.90	4.20	1.40	0.24	M6	0.94	0.93	1.30	0.31	0.20	0.81
3/4	3.50	4.00	5.60	0.63	2.10	4.90	1.69	0.30	M6	1.22	1.08	1.54	0.39	0.26	1.19
1	3.50	4.50	6.40	0.86	2.40	5.70	2.12	0.36	M8	1.72	1.27	1.67	0.47	0.31	2.38
1 1/2	4.50	5.50	7.20	1.36	3.20	7.40	2.75	0.49	M10	2.19	1.76	2.51	0.54	0.38	4.56
2	5.00	6.25	7.60	1.86	3.60	7.40	3.11	0.49	M10	2.71	1.76	3.21	0.54	0.38	7.00
2 1/2	6.75	-	10.00	2.35	4.90	11.90	4.25	0.72	1/2	3.51	2.49	4.13	0.78	0.47	16.50
3	7.75	-	11.00	2.86	5.40	11.90	4.60	0.72	5/8	4.14	2.49	4.80	0.78	0.47	23.00
4	9.50	-	12.00	3.81	6.20	12.40	5.68	1.02	5/8	6.37	2.52	5.88	0.94	0.59	42.00
6*	13.28	-	19.50	5.78	10.60	17.25	8.92	2.54	3/4	11.13	3.54	8.60	1.10	1.10	126.00

* 6" CAD drawings available upon request or at www.ballvalve.com



Cleaning &
Electropolishing



Sanitary Products



Automation
Systems

317F Ordering Information

Example: 2" Full Port Sanitary Ball Valve with Lever Handle and Locking Device, 316SS Body and Trim, PTFE Seats and Seals, 316SS Clamp Ends, 25 Ra Max Mech. Polish (ID)

Valve Series	Valve Size	Body Material	End Material	Ball Material	Stem Material	Seat	Seal	End Connections	Port	Ball Config.	Surface Finish
317F - Full Port	2* 1/4" 3* 3/8" 5 1/2"	6 - A351 Gr. CF8M (316)	6 - A351 Gr. CF8M (316)	6 - A351 Gr. CF8M (316)	6 - A351 Gr. CF8M (316)	T - PTFE K - PTFE Cavity Filled	T - PTFE M - TFM N - TFM 1-Piece Seat/ Body Seal	O - Tube O.D. Butt Weld C - Clamp (316) P - Compression E - Extended Tube O.D. Butt Weld A - ANSI 150# (316) T - NPT R - I-Line K - Tank Bottom L - Long Clamp	2 - 2 Way	S - Straight Port	None - 25 Ra Max, Mech. Polish SFV1 - 20 Ra Max, Mech. Polish SFV3 - 30 Ra Max, Mech. Polish SFV4 - 15 Ra Max, Electropolish SFV5 - 20 Ra Max, Electropolish SFV6 - 25 Ra Max, Electropolish
317C - Compression	7 3/4" A 1" C 1 1/2" D 2" E 2 1/2" F 3" G 4" I 6"		3 - A351 Gr. CF3M (316L)			M - TFM J - TFM Cavity Filled N - TFM 1-Piece Seat/Body Seal					

* tube butt weld, extended weld, and compression end only

Due to continuous product development, information may change without notice.



INLINE INDUSTRIES, INC.

4701-A Littlejohn Street
Baldwin Park, CA 91706
Tel: (800) 568-8998
(626) 813-6188
Fax: (626) 813-6186
www.ballvalve.com
info@ballvalve.com

Distributed by: