

384 High Alloy Ball Valve

3-Piece Full and Standard Port
ISO 5211 Direct Mount Pad



For Automated &
Manual Service

General Chemical

Industrial

Other Corrosion
Resistant Applications

The 384 Series Ball Valve

The 384 series High Alloy ball valve incorporates several innovative design features for improved process performance. The dual pattern ISO 5211 mounting pad facilitates direct mounting of pneumatic and electric actuators. In combination with our high-cycle, live-loaded stem packing system, the 384 series ball valve provides an ideal choice for all your automation requirements.

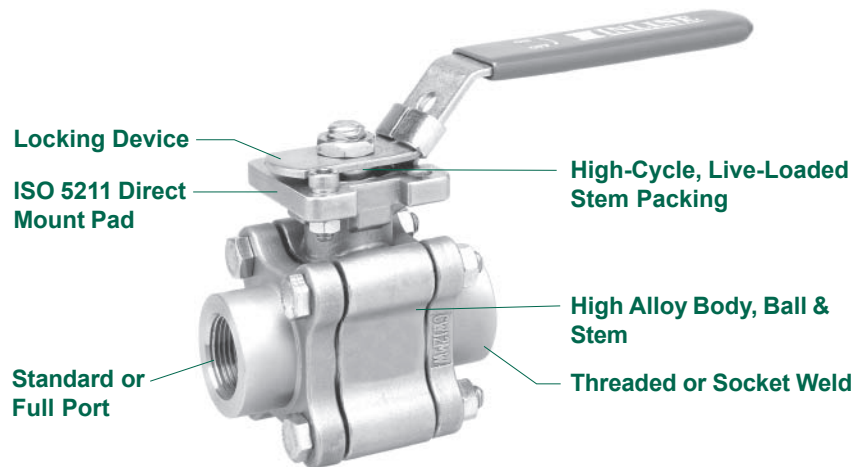

Standard Features and Benefits

- **Dual Pattern ISO 5211 Direct Mount Pad**
 - No bracket or drive coupling needed for automation
 - Dual pattern pad fits a wide range of actuator sizes
 - Eliminates exposed moving parts for safer work environment
 - Prevents side-loading and improves actuator positioning
- **High-Cycle, Live-Loaded Stem Packing**
 - Spring energized stem seals self-adjust to compensate for wear, pressure/temperature changes ensuring a leak-tight seal and extending service life
- **O-Ring Stem Bearing**
 - Maintains stem alignment
 - Reduces packing side-loading and wear
 - Enhances stem seal performance
- **Blow-Out-Proof Stem**
 - Stem is bottom loaded to prevent removal when valve is in service
- **Universal Valve Body**
 - Same center section can be used for both manual and automated service
- **Lockout Capability**
 - Enables plant personnel to secure valve in open or closed position when manually operated
- **Heavy Duty Construction**
 - Made to full ANSI B16.34 Class 900 dimensions for trouble-free performance over a wide range of service conditions
- **Investment Cast**
 - High quality investment castings improve dimensional control and reduce porosity; certified material test reports are available upon request

Options

- End connections available in NPT or socket weld
- High pressure seats and seals

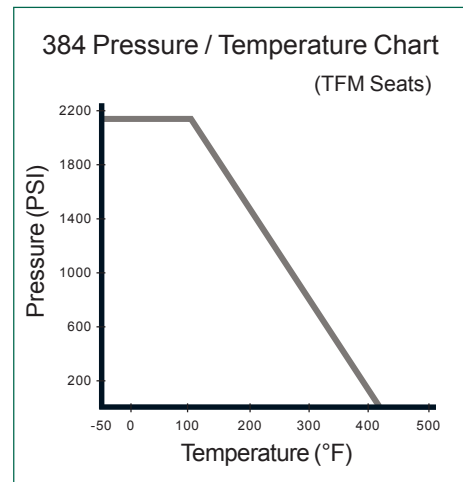

Operating Conditions

- Temperature range:
 - 50°F ~ 425°F
- Maximum pressure:
 - ASME B16.34 Class 900

Specifications

- All valves built and pressure tested to ANSI/ASME B16.34, MSS-SP-110 and API 598
- All materials comply with applicable ASTM material specifications including ASTM-A494
- UNS Number N30002
- End connections: All to B16.34; NPT to B1.20.1; socket weld to B16.11

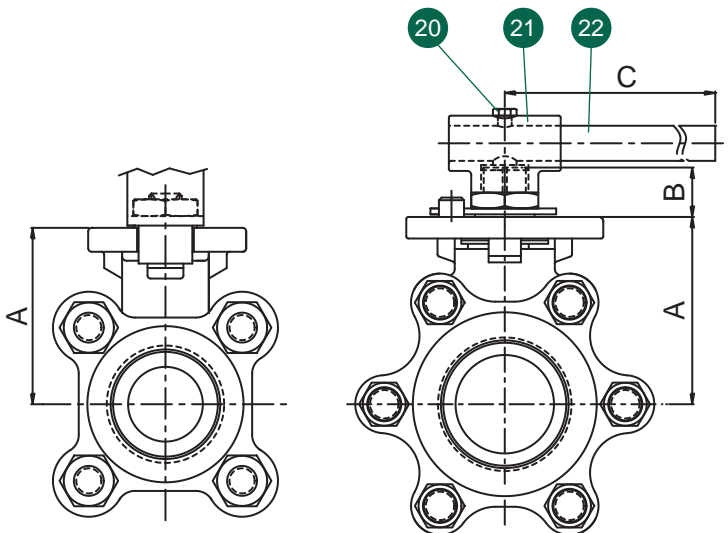

Size: 1/4" - 1-1/2" (Full Port)
1/2" - 2" (Standard Port)

Size: 2" (Full Port)
2-1/2" (Standard Port)

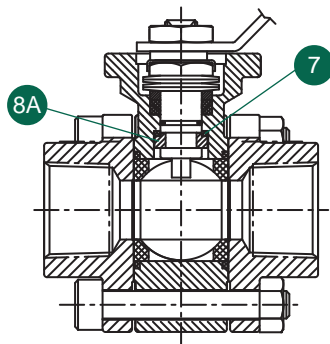
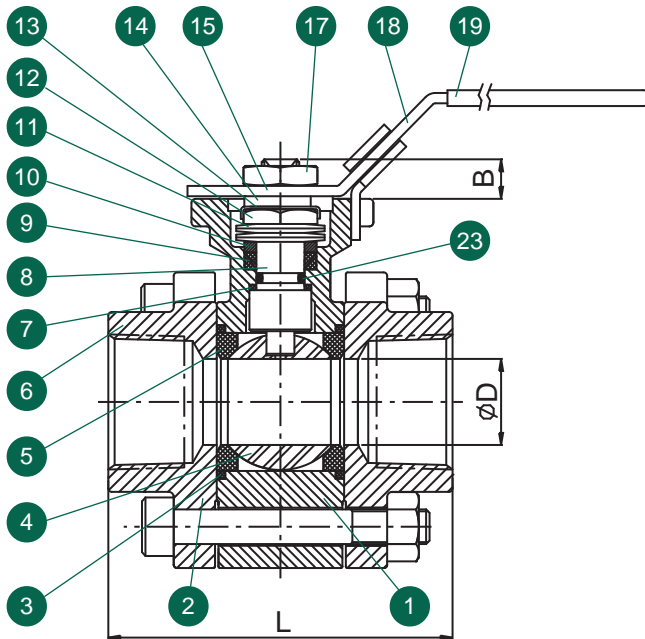
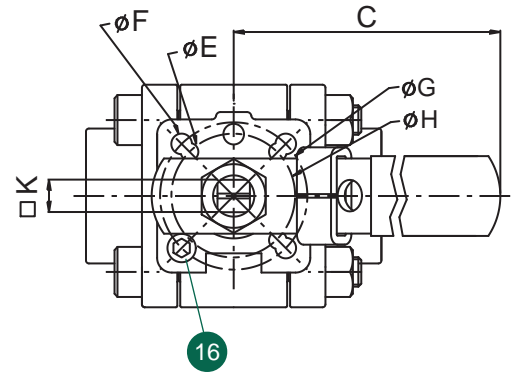

Size: 1/4" - 1/2"
(Full Port)
1/2" - 3/4"
(Standard Port)

Valve Components			
#	Part Name	Material	Qty.
1	Body	High Alloy	1
2	End Cap	High Alloy	2
3	Body Seal	TFM	2
4	Ball	High Alloy	1
5	Seat	TFM	2
6	Body Bolt	304SS	4/6*
7†	Thrust Washer	PEEK	1
8	Stem	High Alloy	1
8A†	Half Split Ring	High Alloy	1
9	Stem Packing Set	TFM	1
10	Gland Washer	304SS	1
11	Disc Washer	301SS	4
12	Stem Nut	304SS	1
13	Nut Stop	304SS	1
14	Space Washer	304SS	1
15	Plater	304SS	1
16	Stop Pin	304SS	1
17	Handle Nut	304SS	1
18	Handle	304SS	1
19	Handle Cover	Vinyl	1
20*	Set Bolt	304SS	1
21*	Lever Head	CF8	1
22*	Lever	Steel Pipe	1
23	O-Ring	Viton	1

† 1/4" - 1/2" (Full Port) *2" (Full Port)
1/2" - 3/4" (Standard Port) 2-1/2" (Standard Port)

Dimensions (Inches)													
Size		A	B	C	D	E	F	G	H	K	L	ISO 5211 Pattern	Wt. (lbs)
384F	384S												
1/4	-	1.81	0.35	5.11	0.43	1.41	1.65	0.23	0.23	0.35	2.63	F03 / F04*	1.75
3/8	-	1.81	0.35	5.11	0.49	1.41	1.65	0.23	0.23	0.35	2.63	F03 / F04*	1.75
-	1/2	1.81	0.35	5.11	0.49	1.41	1.65	0.23	0.23	0.35	2.67	F03 / F04*	1.75
1/2	3/4	1.73	0.35	5.11	0.59	1.41	1.65	0.23	0.23	0.35	3.37	F04 / F05*	2.45
3/4	1	1.88	0.47	6.10	0.78	1.65	1.96	0.23	0.23	0.43	3.77	F04 / F05*	4.40
1	1 1/4	2.08	0.47	6.10	0.98	1.65	1.96	0.23	0.27	0.43	4.21	F05 / F07*	6.05
1 1/4	1 1/2	2.36	0.61	8.07	1.25	1.96	2.75	0.27	0.36	0.55	4.37	F05 / F07*	7.40
1 1/2	2	2.75	0.61	8.07	1.49	1.96	2.75	0.27	0.36	0.55	5.07	F07 / F10*	11.35
2	2 1/2	3.42	0.82	11.81	1.96	2.75	4.01	0.36	0.44	0.66	6.10	F07 / F10*	23.30



Automation Systems



Direct Mount Product

384 Ordering Information

Example: 2" 3-Piece Standard Port Direct Mount Ball Valve, ISO 5211 Direct Mount Pad with Lever Handle and Locking Device, Alloy-C Body and Trim, TFM Seats, TFM Seals, NPT Ends

Valve Series	Valve Size	Body Material	End Material	Ball Material	Stem Material	Seat	Seal	End Connection	Port	Ball Config.
384S - Standard Port	2 [†] 1/4" 3 [†] 3/8" 5 1/2"	8 - Alloy-C ASTM 494 Type	8 - Alloy-C ASTM 494 Type	8 - Alloy-C ASTM 494 Type	8 - Alloy-C ASTM 494 Type	M - TFM	M - TFM	T - NPT S - Socket Weld	2 - 2 Way	S - Straight Port
384F - Full Port	7 3/4" A 1" B 1 1/4" C 1 1/2" D 2" E* 2 1/2"	CW12MW 5 - Alloy 20 ** J - 254 SMO **	CW12MW 5 - Alloy 20 ** J - 254 SMO **	CW12MW 5 - Alloy 20 ** J - 254 SMO **	CW12MW 5 - Alloy 20 ** J - 254 SMO **					

[†] Full Port Only

* Standard Port Only

** Minimum order may apply

Due to continuous product development, information may change without notice.



Distributed by:

INLINE INDUSTRIES, INC.

4701-A Littlejohn Street
Baldwin Park, CA 91706
Tel: (626) 813-6188
Fax: (626) 813-6186
www.ballvalve.com
info@ballvalve.com

© 2009 Inline Industries. All rights reserved.

0908.1