

AE-Series

Electric Actuators



Features and Benefits

- 1 Permanently Lubricated Heavy Duty Aluminum Alloy Steel Gear Train
- 1 NEMA 4, 4X Weatherproof Enclosure
- 1 ISO 5211 Direct Mount Capabilities
- 1 Manual Override (except on the M25)
- 1 1/2" NPT Conduit Entries (2)
- 1 Adjustable Travel Stops
- 1 Standard 25% Duty Cycle
- 1 Thermal Overload Protection
- 1 Standard 110V AC Single Phase
- 1 2 Limit Switches

Options

- 1 12V / 24V AC/DC, 220V AC
- 1 220V AC Three-Phase
- 1 Reversing Motors
- 1 Extended Duty Motors for Modulating Service
- 1 Heater and Thermostat
- 1 Extra Limit Switches (up to 2)
- 1 Remote Control Indicators



Performance Chart

12V / 24V												
Model No.	Torque (in-lbs)	Cycle Time (90°)		Motor Power	Motor Speed		12V DC/AC			24V DC/AC		
					12V	24V	Run	Start	Lock	Run	Start	Lock
M10	310	15 s		10W	3600/min	3600/min	0.5A	3.0A	3.0A	0.6A	0.8A	1.4A
M16	443	20 s		10W	3600/min	3600/min	0.5A	3.0A	3.0A	0.7A	0.8A	1.4A
M20	797	15 s		70W	1800/min	1800/min	3.4A	5.0A	8.5A	3.0A	5.0A	13.0A
M30	1328	22 s		70W	1800/min	1800/min	3.4A	5.0A	8.5A	3.0A	5.0A	13.0A
M40	3540	16 s		180W	1800/min	1800/min	12.0A	8.5A	30.0A	6.0A	8.0A	30.0A
M50	4420	22 s		180W	1800/min	1800/min	13.0A	8.5A	30.0A	6.5A	8.0A	30.0A
M60	5735	28 s		180W	1800/min	1800/min	14.0A	8.5A	30.0A	7.5A	8.0A	30.0A
Single-Phase												
Model No.	Torque (in-lbs)	Cycle Time (90°)		Motor Power	Motor Speed		110V Current			220V Current		
		60 Hz	50 Hz		60 Hz	50 Hz	Run	Start	Lock	Run	Start	Lock
M10	310	12 s	13 s	10W	3600/min	3000/min	0.5A	1.5A	0.6A	0.3A	1.0A	0.5A
M16	443	20 s	24 s	10W	3600/min	3000/min	0.5A	1.5A	0.6A	0.3A	1.0A	0.5A
M20	797	15 s	17 s	40W	1720/min	1450/min	1.3A	3.0A	1.8A	0.5A	1.5A	0.9A
M25	1063	8 s	10 s	40W	1720/min	1450/min	1.0A	3.0A	1.8A	0.5A	1.5A	0.9A
M30	1328	22 s	26 s	40W	1720/min	1450/min	1.0A	3.0A	1.8A	0.5A	1.5A	0.9A
M40	3540	16 s	18 s	120W	1720/min	1420/min	1.3A	3.1A	3.6A	0.6A	1.5A	1.8A
M50	4420	22 s	25 s	120W	1720/min	1450/min	1.5A	3.0A	3.6A	0.7A	1.5A	1.8A
M60	5735	28 s	31 s	120W	1720/min	1450/min	1.8A	3.0A	3.6A	0.8A	1.5A	1.8A
Three-Phase												
Model No.	Torque (in-lbs)	Cycle Time (90°)		Motor Power	Motor Speed		220V Current					
		60 Hz	50 Hz		60 Hz	50 Hz	Run	Start	Lock			
M20	797	15 s	17 s	40W	1720/min	1450/min	0.6A	1.8A	1.1A			
M25	1063	8 s	10 s	40W	1720/min	1450/min	0.6A	1.8A	1.1A			
M30	1328	22 s	26 s	40W	1720/min	1450/min	0.6A	1.8A	1.1A			
M40	3540	16 s	18 s	120W	1720/min	1450/min	1.0A	3.0A	3.5A			
M50	4420	22 s	25 s	120W	1720/min	1450/min	1.0A	3.0A	3.5A			
M60	5735	28 s	31 s	120W	1720/min	1450/min	1.0A	3.0A	3.5A			

M10

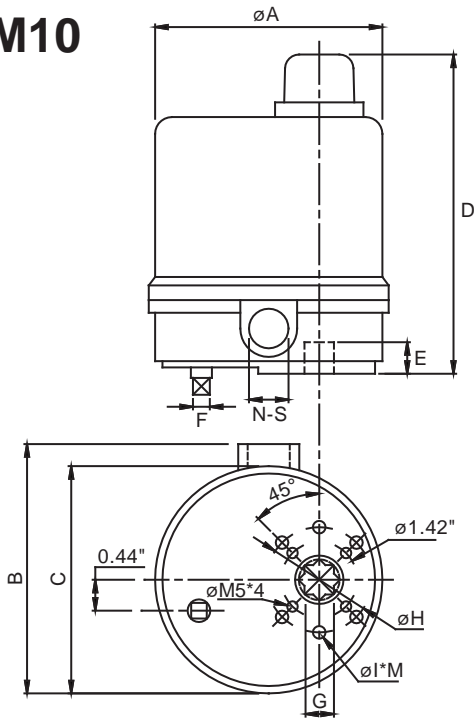

M16

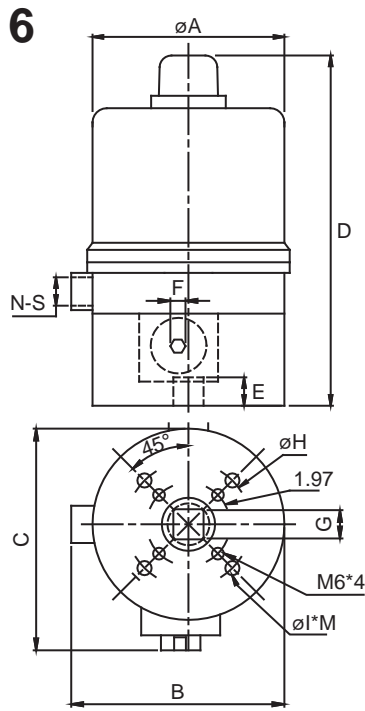

M20

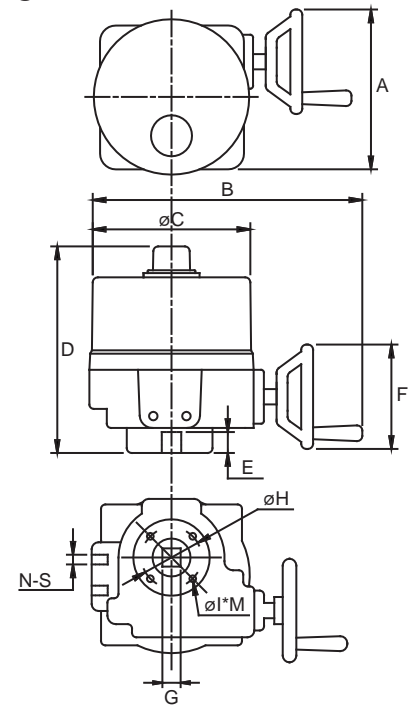

M25

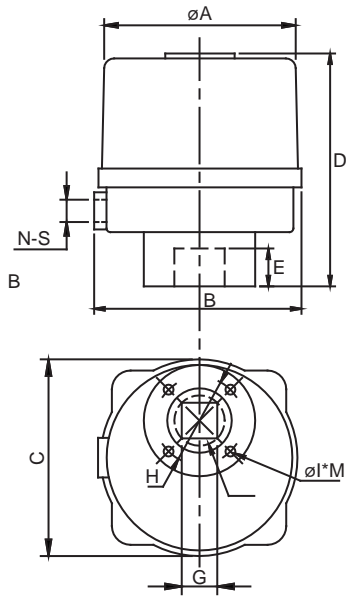

M30 - M60

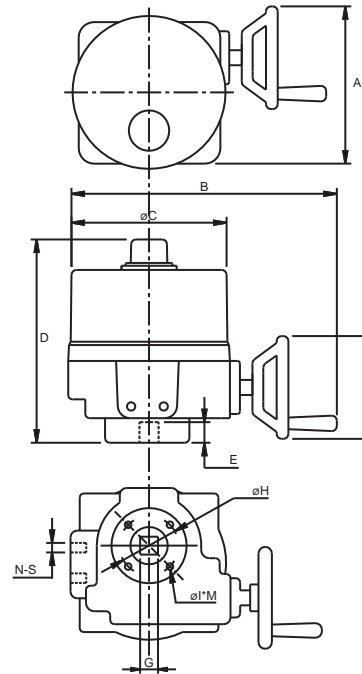

Dimensions (Inches)														
Model	A	B	C	D	E	F	G	H	I	M	N	S	Flange Type	Weight (lbs)
M10	4.25	4.80	4.25	6.10	0.59	0.31	0.55	1.97	M6	6	1	1/2	F03 / F05	4.40
M16	4.49	4.80	4.77	7.99*	0.63	0.20	0.67	2.76	M8	4	1	1/2	F05 / F07	6.60
M20	7.87	12.99	7.87	10.04	1.18	4.92	0.87	2.76	M8	4	2	1/2	F07	24.40
M25	6.06	6.30	6.06	7.56	1.18	-	0.87	2.76	M8	4	1	1/2	F07	9.90
M30	7.87	12.99	7.87	10.04	1.18	4.92	0.87	2.76	M8	4	2	1/2	F07	24.40
M40	11.81	14.96	9.21	12.40	1.57	7.68	1.42	4.02	M10	4	2	1/2	F10	48.40
M50	11.81	14.96	9.21	12.40	1.57	7.68	1.42	4.02	M10	4	2	1/2	F10	48.40
M60	11.81	14.96	9.21	12.40	1.57	7.68	1.42	4.02	M10	4	2	1/2	F10	48.40

* D = 9.17" with modulating card

For information on 75% duty cycle, please contact us

Wiring Diagram
M-10 & M-16 12V/24V AC
Two Positions*

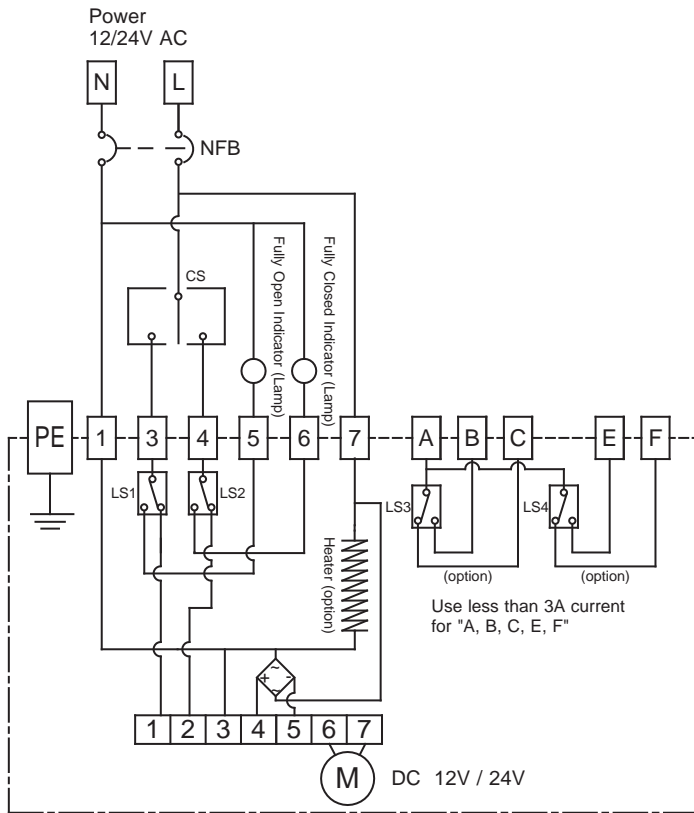

Wiring Diagram
M-20 ~ M-80 24V AC
Two Positions*

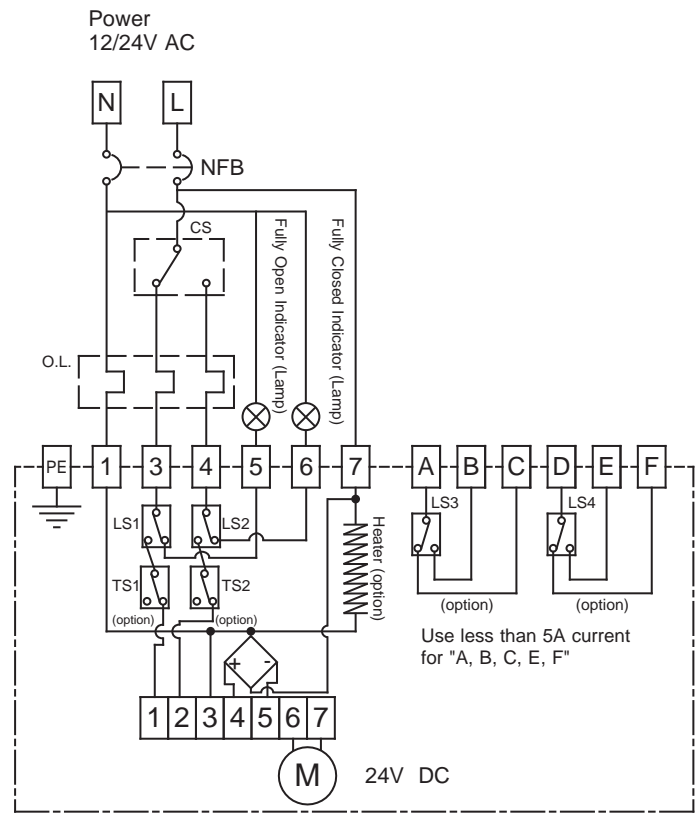

Wiring Diagram
M-10 & M-16 12V/24V DC
Two Positions*

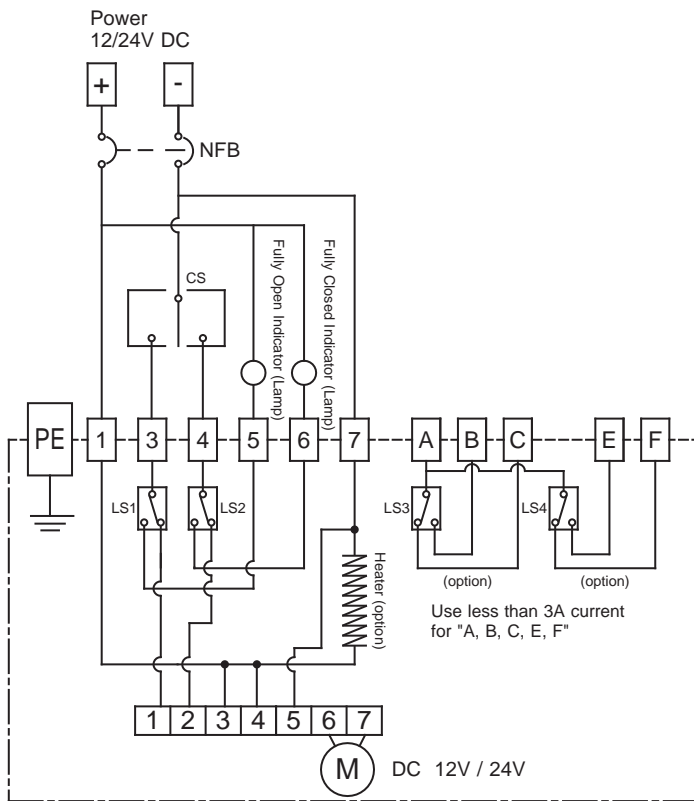

Wiring Diagram
M-20 ~ M-60 12V/24V DC
Two Positions*

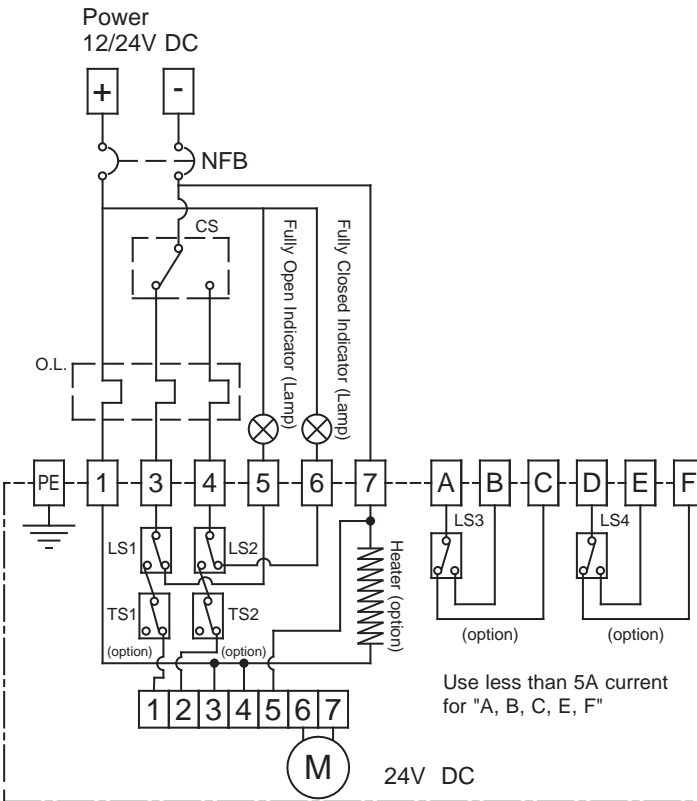

*Note:

NFB -- Power Brake	LS -- Limit Switch	(3) "L" or "-" 7 connect to 3 for OPEN	(6) Fully Close Lamp ON
O.L. -- Overload Protector	TS -- Torque Switch (option)	(4) "L" or "-" 7 connect to 3 for CLOSE	(7) "L" or "-" connect to 7 for HEATER (option)
CS -- Selector Switch or Relay	(1) "N" or "+" connect to 1	(5) Fully Open Lamp ON	

**Wiring Diagram
M-10 & M-16 110V/220V AC
Two Positions***

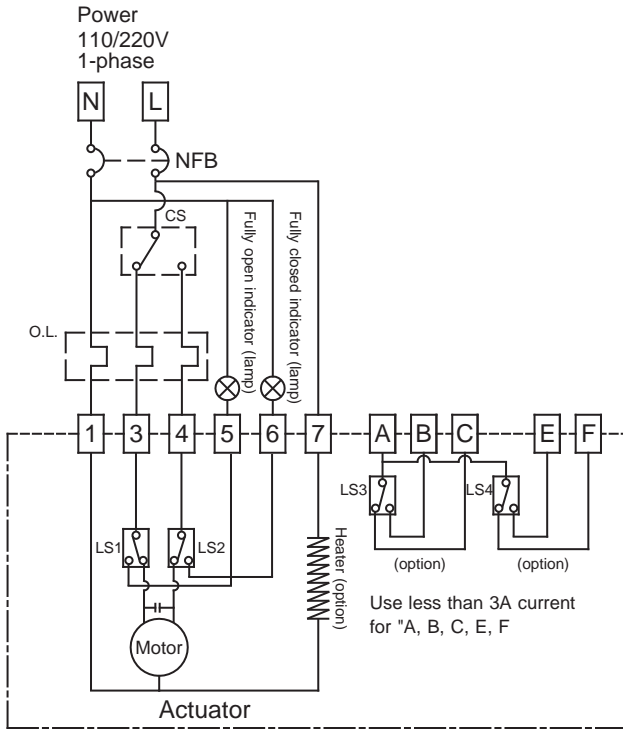

**Wiring Diagram
M-20 ~ M-60 110V/220V AC 1-PH
Two Positions***

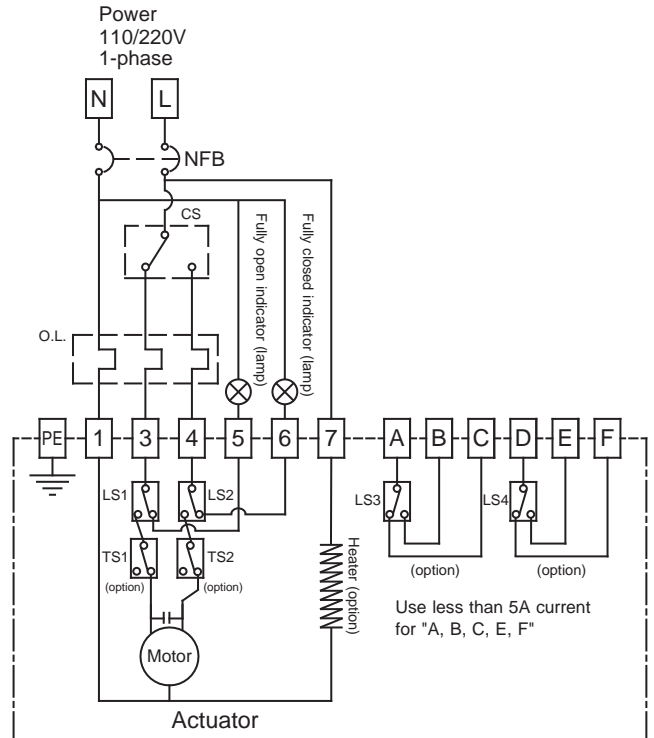

**Wiring Diagram
M-20 ~ M-60 220V AC 3-PH
Two Positions***

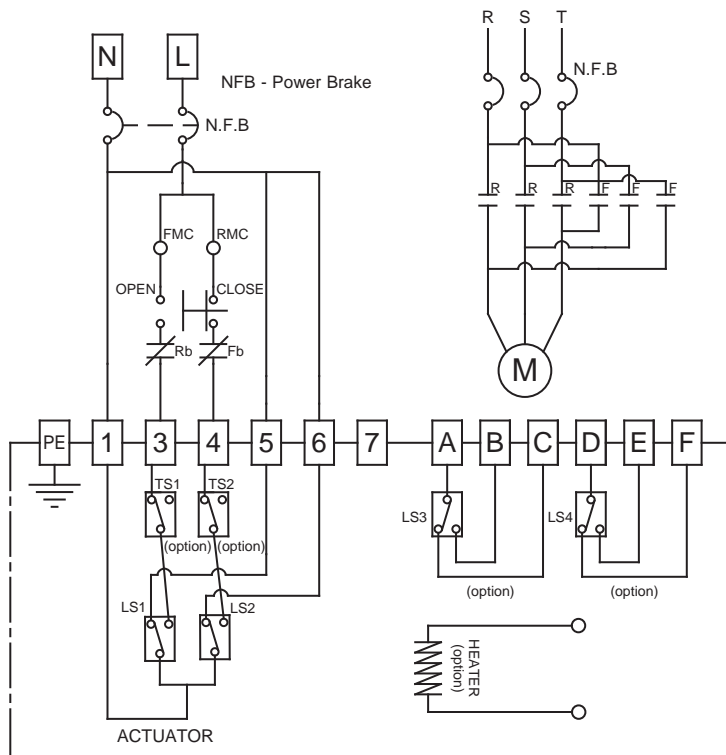

**Wiring Diagram
M-10 & M-16 110V/220V AC
Modulating Service**

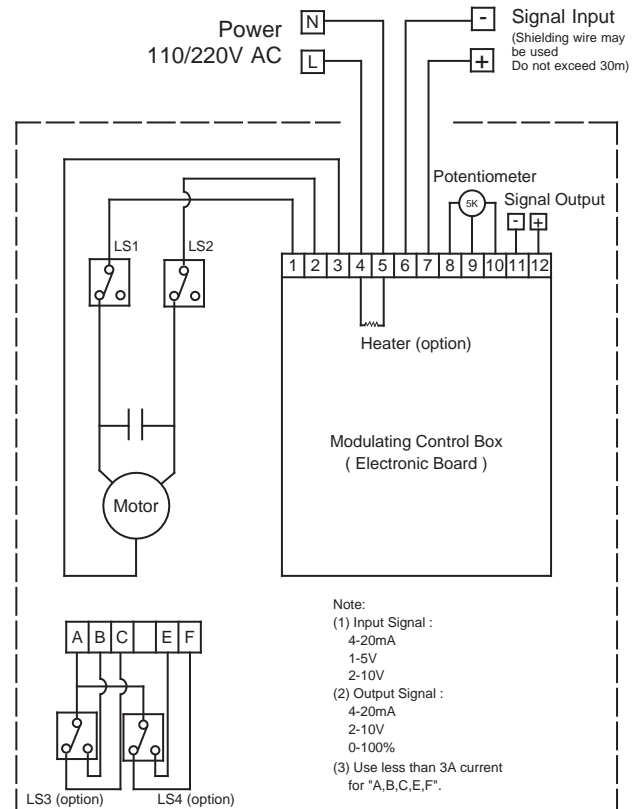

*Note:
 NFB -- Power Brake LS -- Limit Switch (3) "L" or "-" 7 connect to 3 for OPEN (6) Fully Close Lamp ON
 O.L. -- Overload Protector TS -- Torque Switch (option) (4) "L" or "-" 7 connect to 3 for CLOSE (7) "L" or "-" connect to 7 for HEATER (option)
 CS -- Selector Switch or Relay (1) "N" or "+" connect to 1 (5) Fully Open Lamp ON

Wiring Diagram
M-10 & M-16 12V/24V AC/DC
Modulating Service

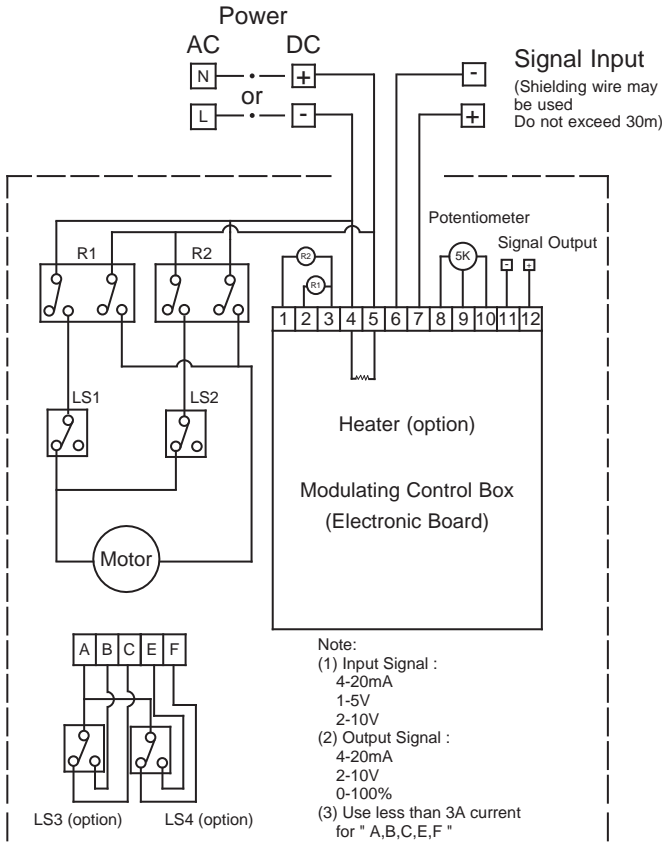

Wiring Diagram
M-20 ~ M-60 24V AC
Modulating Service

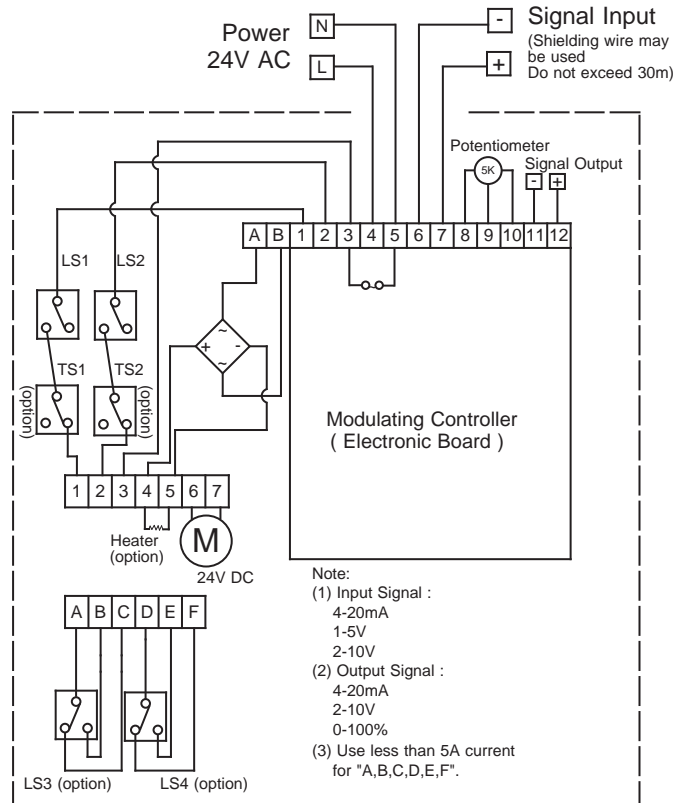

Wiring Diagram
M-20 ~ M-60 24V DC
Modulating Service

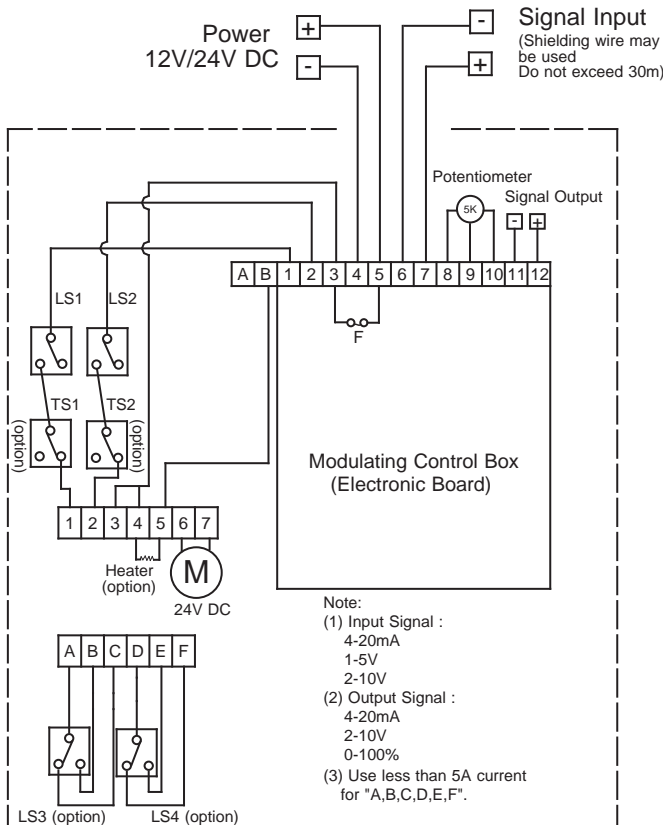

Wiring Diagram
M-20 ~ M-60 110V/220V AC
Modulating Service

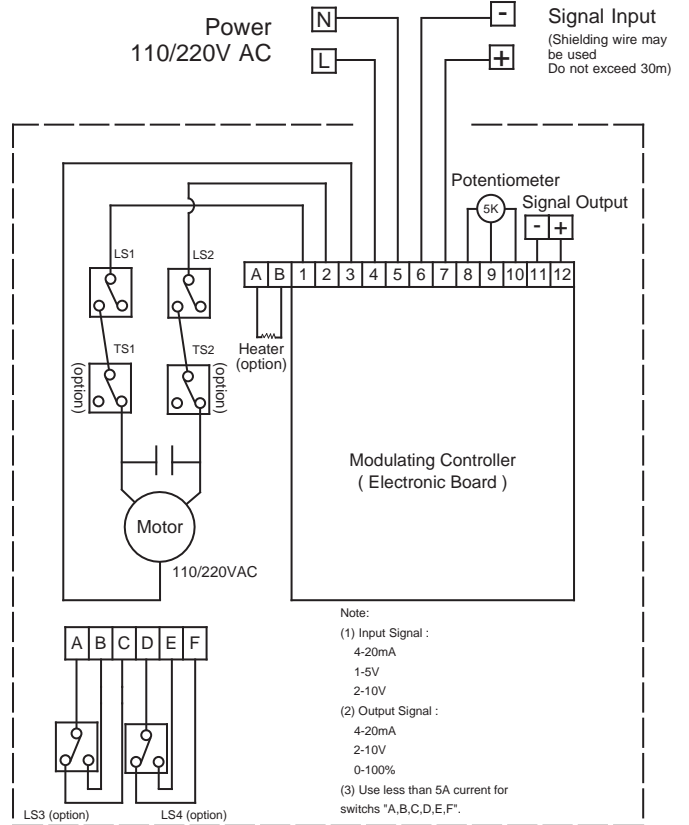

Modulating Control Board

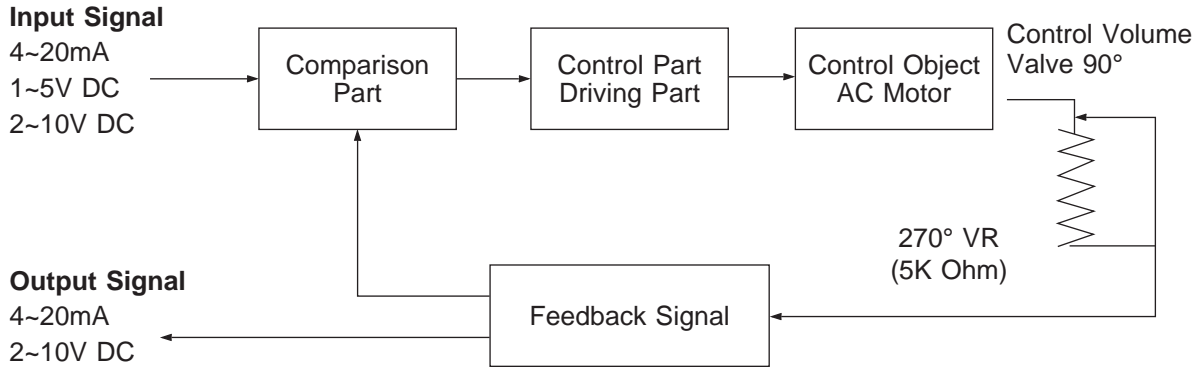

Modulating Control Board for M10, M16

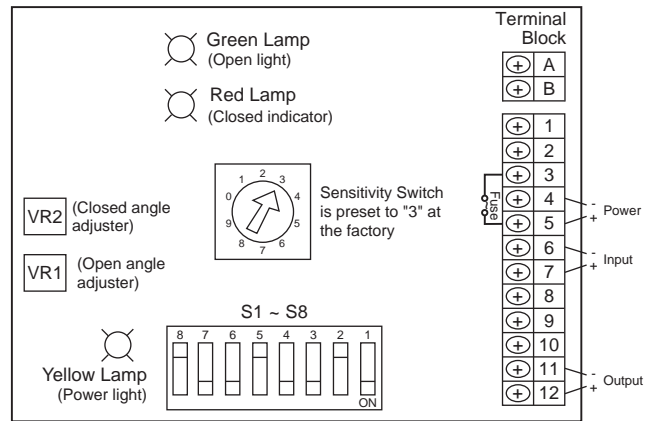
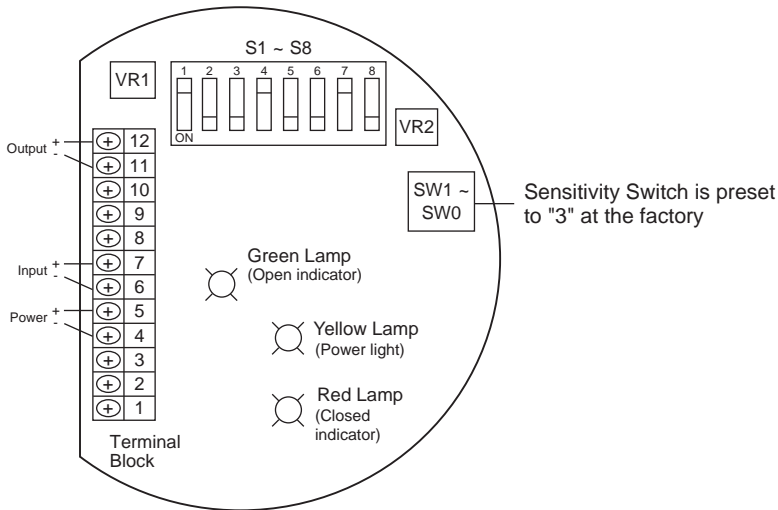

Modulating Control Board for M20 ~ M60

Switch Settings

ATTENTION: TURN POWER OFF BEFORE CHANGING THE FOLLOWING SETTINGS:

S1,2: INPUT SIGNAL SELECT
 " 4~20mA " set 1-ON / 2-OFF
 " 1~5V " set 1-OFF / 2-OFF
 " 2~10V " set 1-OFF / 2-ON

S3,4,5: OUTPUT SIGNAL SELECT
 "2-10V" set 3-ON / 4-OFF / 5-ON
 "4-20mA" set 3-OFF / 4-ON / 5-OFF

S6: Valve is fully-open when the input signal is 4mA, 2V or 1V and valve is fully-closed when the input signal is 20mA, 10V or 5V, set 6-ON
 Valve is fully-closed when the input signal is 4mA, 2V or 1V and valve is fully-open when the input signal is 20mA, 10V or 5V, set 6-OFF

S7,8: POSITION SELECT (when the feedback signal fails)
 "valve fully-closed" set 7-OFF / 8-ON
 "valve fully-open" set 7-ON / 8-OFF
 "valve stops" set 7-ON / 8-ON

SW1~0: Sensitivity Switch

The 0~90° rotation can be divided into incremental movements as follows:

Setting	1	2	3	4	5	6	7	8	9	0
# of incremental movements	80	73	66	59	52	45	38	31	24	17

Ordering Information

AE	M10	A	4	0	15	0
Series	Model	Current	Enclosure	Duty	Cycle Time	Option
AE - Actuator Electric	M10 M16 M20 M25 M30 M40 M50 M60	A - 24V AC B - 110V AC C - 220V AC D - 12V DC E - 24V DC	4 - NEMA 4, 4X	0 - None 25 - 25% 75 - 75%	8 12 15 16 20 22 24 34 35 46	0 - None T - Thermometer H - Heater S1 - 1 extra switch S2 - 2 extra switches 3 - Three-Phase* Modulating Control Boards ** M1 - 4~20mA in, 2~10V out M2 - 4~20mA in, 4~20mA out M3 - 1~5V in, 2~10V out M4 - 1~5V in, 4~20mA out M5 - 2~10V in, 2~10V out M6 - 2~10V in, 4~20mA out

* Three-Phase available on M20 through M60 only

** Modulating control boards used with 75% duty cycle only

Due to continuous product development, information may change without notice.



INLINE INDUSTRIES, INC.

4701-A Littlejohn Street
Baldwin Park, CA 91706
Tel: (626) 813-6188
Fax: (626) 813-6186
www.ballvalve.com
info@ballvalve.com

Distributed by: